



BUREAU
VERITAS

EMC Test Report

Report No.: EMC_SL20070901-BW-001_NBGL_CE

Test Model: Note-NBGL

Received Date: 9/22/2020

Test Date: 9/24/2020, 9/27/2020, 9/28/2020, 9/29/2020, 9/30/2020

Issued Date: 10/2/2020

Applicant: Blues Wireless

Address: 50 Harbor Street, Manchester, MA 01944, United States

Manufacturer: Blues Wireless

Address: 50 Harbor Street, Manchester, MA 01944, United States

Issued By: Bureau Veritas Consumer Products Services, Inc.

Lab Address: 775 Montague Expressway, Milpitas, CA 95035, USA

Test Location(1): 775 Montague Expressway, Milpitas, CA 95035, USA



This report is for your exclusive use. Any copying or replication of this report to or for any other person or entity, or use of our name or trademark, is permitted only with our prior written permission. The test report shall not be reproduced except in full, without written approval of the laboratory. This report sets forth our findings solely with respect to the test samples identified herein. The results set forth in this report are not indicative or representative of the quality or characteristics of the lot from which a test sample was taken or any similar or identical product unless specifically and expressly noted. Our report includes all of the tests requested by you and the results thereof based upon the information that you provided to us. You have 60 days from date of issuance of this report to notify us of any material error or omission caused by our negligence, provided, however, that such notice shall be in writing and shall specifically address the issue you wish to raise. A failure to raise such issue within the prescribed time shall constitute your unqualified acceptance of the completeness of this report, the tests conducted and the correctness of the report contents. Unless specific mention, the uncertainty of measurement has been explicitly taken into account to declare the compliance or non-compliance to the specification. The report must not be used by the client to claim product certification, approval, or endorsement by any government agencies.

Table of Contents

Release Control Record	4
1 Certificate of Conformity	5
2 Summary of Test Results	6
2.1 Measurement Uncertainty	7
2.2 Modification Record	7
3 General Information	8
3.1 General Description of EUT	8
3.2 Features of EUT	8
3.3 Operating Modes of EUT and Determination of Worst Case Operating Mode	9
3.4 Test Program Used and Operational Description	9
3.5 Primary Clock Frequencies of Internal Source	9
3.6 Miscellaneous	10
4 Configuration and Connections with EUT	11
4.1 Connection Diagram of EUT and Peripheral Devices	11
4.2 Configuration of Peripheral Devices and Cable Connections	12
5 Conducted Disturbance at Mains Ports	13
5.1 Limits	13
5.2 Test Instruments	13
5.3 Test Arrangement	13
5.4 Test Results	14
6 Conducted Disturbance at Telecommunication Ports	16
7 Radiated Disturbance up to 1 GHz	17
7.1 Limits	17
7.2 Test Instruments	17
7.3 Test Arrangement	18
7.4 Test Results	19
8 Radiated Disturbance above 1 GHz	20
8.1 Limits	20
8.2 Test Instruments	20
8.3 Test Arrangement	21
8.4 Test Results	22
9 Harmonics Current Measurement	23
10 Voltage Fluctuations and Flicker Measurement	24
11 General Immunity requirements	25
11.1 Performance Criteria	26
12 Electrostatic Discharge Immunity Test (ESD)	33
13 Radiated, Radio-frequency, Electromagnetic Field Immunity Test (RS)	34
13.1 Test Specification	34
13.2 Test Instruments	34
13.3 Test Arrangement	35
13.4 Test Results	36
14 Electrical Fast Transient/Burst Immunity Test (EFT)	37
14.1 Test Specification	37



14.2	Test Instruments.....	37
14.3	Test Arrangement.....	37
14.4	Test Results	38
15	Surge Immunity Test.....	39
16	Immunity to Conducted Disturbances Induced by RF Fields (CS).....	40
16.1	Test Specification	40
16.2	Test Instruments.....	40
16.3	Test Arrangement.....	40
16.4	Test Results	41
17	Power Frequency Magnetic Field.....	42
18	Voltage Dips and Interruptions.....	42
19	Pictures of Test Arrangements	43
19.1	EUT Photos.....	43
19.2	Conducted Emission from the DC Mains Power Port.....	44
19.3	Radiated Emission at Frequencies up to 1GHz.....	45
19.4	Radiated Emission at Frequencies above 1GHz.....	46
19.5	Radio-frequency, Electromagnetic Field Immunity Test (RS) up to 1GHz.....	47
19.6	Radio-frequency, Electromagnetic Field Immunity Test (RS) above 1GHz	48
19.7	Electrical Fast Transient/Burst Immunity Test (EFT) Power Port.....	49
19.8	Conducted Disturbances Induced by RF Fields (CS) Power Port.....	50
19.9	Appendix – Information of the Testing Laboratories	51



Release Control Record

Issue No.	Description	Date Issued
EMC_SL20070901-BW-001_NBGL_CE	Original Report	10/2/2020



1 Certificate of Conformity

Product: Notecard

Brand: Blues Wireless

Test Model: Note-NBGL

Sample Status: Test Sample

Applicant: Blues Wireless

Test Date: 9/24/2020, 9/27/2020, 9/28/2020, 9/29/2020, 9/30/2020

Standards: EN 55032:2015, Class B
EN 55035:2017
EN 301 489-1 V2.2.1 (2019-03)
EN 301 489-50 V2.2.1 (2019-04)
EN 301 489-52 V1.1.0 (2016-11)
EN 61000-4-3:2006 +A1:2008 +A2:2010
EN 61000-4-4:2012
EN 61000-4-6:2014

The above equipment has been tested by Bureau Veritas Consumer Products Services, Inc. Milpitas Branch, and found compliance with the requirement of the above standards. The test record, data evaluation & Equipment under Test (EUT) configurations represented herein are true and accurate accounts of the measurements of the sample's EMC characteristics under the conditions specified in this report.

Prepared by :  , Date: 10/2/2020
Alok Patel, Electrical Test Engineer

Approved by :  , Date: 10/2/2020
George Hsu, Lead EMC Test Engineer

2 Summary of Test Results

EN 55032:2015/EN 301 489 Series Emissions				
Basic Standard	Phenomenon	Application	Result/Remarks	Verdict
EN 55032:2015	Radiated emission 30-1000 MHz	Enclosure of ancillary equipment measured on a stand alone basis	Minimum passing Class B margin is 2.5 dB at 117.968 MHz.	Pass
	Radiated emission 1-6 GHz		Minimum passing Class B margin is 16.5 dB at 2002.841 MHz.	Pass
EN 55032:2015	Conducted emission 150 kHz - 30 MHz	DC power input/output ports (fixed)	Minimum passing Class B margin is -13.39 dB at 0.227 MHz.	Pass
EN 55032:2015	Conducted emission 150 kHz - 30 MHz	AC mains input/output ports	Test not applicable because the port does not exist.	N/A
EN 61000-3-2:2014* EN 61000-3-2:2006 +A1:2009 +A2:2009	Harmonic current emissions	AC mains input port	Test not applicable because the port does not exist.	N/A
EN 61000-3-3:2013* EN 61000-3-3:2008	Voltage fluctuations and flicker	AC mains input port	Test not applicable because the port does not exist.	N/A
EN 55032:2015	Conducted disturbance 150 kHz - 30 MHz	Telecommunication ports	EUT does not contain telecom ports	N/A

EN55035/EN 301 489 Series Immunity				
Basic Standard	Phenomenon	Application	Result/Remarks	Verdict
EN 61000-4-3:2006 +A1:2008 +A2:2010	RF Electromagnetic Field (RS)	Enclosure	Performance Criterion A	Pass
EN 61000-4-2:2009	Electrostatic Discharges (ESD)	Enclosure	Not tested, EUT is internal component used inside of other devices.	N/A
EN 61000-4-4:2012* EN 61000-4-4:2004 +A1:2010	Fast Transients Common Mode (EFT)	Signal, telecommunication and control ports, DC and AC power ports	Performance Criterion A	Pass
EN 61000-4-5:2014* EN 61000-4-5:2006	Surges	AC mains power input ports, line to line and line to ground Telecommunication ports, line to ground	Test not applicable EUT does not have AC power port.	N/A
EN 61000-4-6:2014* EN 61000-4-6:2009	RF Common Mode 150 kHz to 80 MHz (CS)	Signal, telecommunication and control ports, DC and AC power ports	Performance Criterion A	Pass
EN 61000-4-8:2010	Power Frequency Magnetic Field (PFMF)	Enclosure	Test not applicable because the EUT does not contain components inherently susceptible to magnetic fields	N/A

EN55035/EN 301 489 Series Immunity				
Basic Standard	Phenomenon	Application	Result/Remarks	Verdict
EN 61000-4-11:2004 +A1:2017	Voltage Dips and Interruptions	AC mains power input ports	Test not applicable not have AC power port.	N/A

N/A: Not Applicable

* Both the specific and the latest version of the basic standard are referenced to fulfill the requirements.

Note:

1. There is no deviation to the applied test methods and requirements covered by the scope of this report.
2. Please note for conducted emissions passing values are expressed as negative values while for radiated emissions passing values are expressed as positive values.
3. Determining compliance based on the results of the compliance measurement, not taking into account measurement instrumentation uncertainty.

2.1 Measurement Uncertainty

Where relevant, the following measurement uncertainty levels have been estimated for tests performed on the EUT as specified in CISPR 16-4-2:

Measurement	Expanded Uncertainty (k=2) (±)
Conducted disturbances, 150kHz ~ 30MHz	3.856 dB
Radiated disturbance, 30MHz ~ 1GHz	4.638 dB
Radiated disturbance, 1GHz ~ 6GHz	4.580 dB

The other instruments specified are routine verified to remain within the calibrated levels, no measurement uncertainty is required to be calculated.

2.2 Modification Record

There were no modifications required for compliance.

3 General Information

3.1 General Description of EUT

Product	Notecard
Brand	Blues Wireless
Test Model	Note-NBGL
Identification No. of EUT	N/A
Sample Status	Test Sample
Operating Software	N/A
Power Supply rating	5.0Vdc

3.2 Features of EUT

The tests reported herein were performed according to the method specified by Blues Wireless, for detailed feature description, please refer to the manufacturer's specifications or user's manual.

3.3 Operating Modes of EUT and Determination of Worst Case Operating Mode

Test modes are presented in the report as below.

Mode	Test Condition
All Tests	
1	Normal Operation

3.4 Test Program Used and Operational Description

During the testing process the EUT was connected to CMW 500 basestation via its supported LTE Bands.

3.5 Primary Clock Frequencies of Internal Source

The highest frequency generated or used within the EUT or on which the EUT operates or tunes is 120 MHz, provided by Blues Wireless, for detailed internal source, please refer to the manufacturer's specifications.

3.6 Miscellaneous

➤ Affix CE marking

The marking must be placed visibly and legibly on the product or, if not possible due to the nature of the product, be affixed to the packaging and the accompanying document. The CE marking shall consist of the initials 'CE' taking the following form:

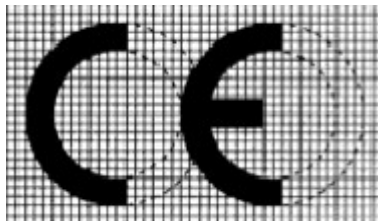

A minimum height of 5 mm is required to ensure that it is legible. However on account of the nature of radio equipment, the height of the CE marking affixed to radio equipment may be lower than 5 mm, provided that it remains visible and legible. If the CE marking is reduced or enlarged, the proportions given in the graduated drawing above must be respected.

When the product is subject to other Directives covering other aspects and which also provide for the 'CE' marking, the accompanying documents must indicate that the product also conforms to those other Directives.

However, when one or more of those Directives allow the manufacturer, during a transitional period, to choose which arrangements to apply, the 'CE' marking has to indicate conformity only with the Directives applied by the manufacturer. In this case, the particularities of the Directives applied, as published in the Official Journal of the European Union, must be given in the documents, notices or instructions required by the Directives and accompanying such products.

.

4 Configuration and Connections with EUT

4.1 Connection Diagram of EUT and Peripheral Devices

All Tests:

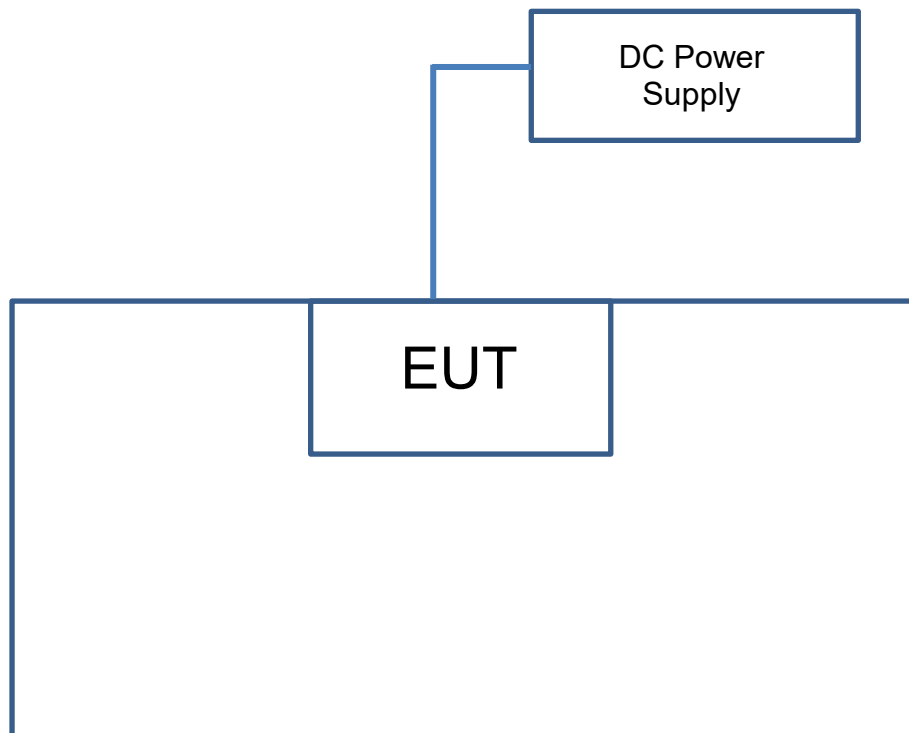



4.2 Configuration of Peripheral Devices and Cable Connections

ID	Product	Brand	Model No.	Serial No.	FCC ID	Remarks
N/A						

Cable Connections to/from EUT.

ID	Description	Qty.	Length (m)	Shielding (Yes/No)	Cores (Qty.)	Remarks
N/A						

5 Conducted Disturbance at Mains Ports

5.1 Limits

Frequency (MHz)	Class A (dBuV)		Class B (dBuV)	
	Quasi-peak	Average	Quasi-peak	Average
0.15 - 0.5	79	66	66 - 56	56 - 46
0.50 - 5.0	73	60	56	46
5.0 - 30.0	73	60	60	50

Notes: 1. The lower limit shall apply at the transition frequencies.
 2. The limit decreases linearly with the logarithm of the frequency in the range of 0.15 to 0.50 MHz.

5.2 Test Instruments

Description & Manufacturer	Model No.	Serial No.	Cal. Date	Cal. Due
EMI Test Receiver Rohde & Schwarz	ESIB 40	100179	11/1/2019	11/1/2020
Transient Limiter Electro-Metrics	EM-7600-5	106	12/31/2019	12/31/2020
LISN ETS-Lindgren	3816/2NM	214372	1/14/2020	1/14/2021

5.3 Test Arrangement

- The EUT was placed 0.4 meters from the conducting wall of the shielded room with EUT being connected to the power mains through a line impedance stabilization network (LISN). Other support units were connected to the power mains through another LISN. The two LISNs provide 50 Ohm/ 50uH of coupling impedance for the measuring instrument.
- Both lines of the power mains connected to the EUT were checked for maximum conducted interference.
- The test results of conducted disturbance at mains ports are recorded of six worst margins for quasi-peak (mandatory) [and average (if necessary)] values against the limits at frequencies of interest unless the margin is 20 dB or greater.

Note:

The resolution bandwidth and video bandwidth of test receiver is 9 kHz for quasi-peak detection (QP) and average detection (AV) at frequency 0.15MHz-30MHz.

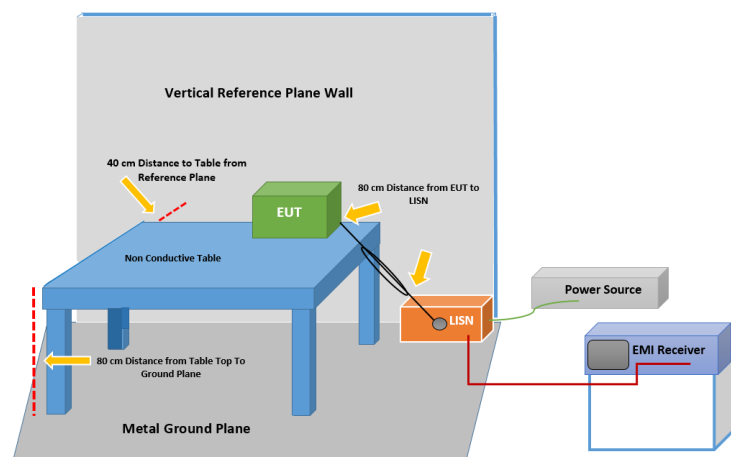



5.4 Test Results

Frequency Range	0.15-30 MHz	Phase	Supply
Input Power	5 Vdc	Environmental Conditions	23 °C, 49% RH
Tested by	Alok Patel	Test Date	9/24/2020
Test Mode	Normal Operation		

No	Frequency (MHz)	Reading Value (dBuV)	Cable Loss (dB)	Insertion Loss (dB)	Emission Level Corrected (dBuV)	Measurement Type	Supply/Return	Limit (dBuV)	Margin (dB)	Pass/Fail
1	0.150386	36.24	9.29	0.04	45.57	Quasi Peak	Supply	65.98	-20.41	Pass
2	0.219619	30.95	9.4	0.04	40.38	Quasi Peak	Supply	62.83	-22.45	Pass
3	2.539471	20.71	9.5	0.06	30.27	Quasi Peak	Supply	56	-25.73	Pass
4	0.306409	24.64	9.44	0.04	34.12	Quasi Peak	Supply	60.07	-25.95	Pass
5	0.408493	20.29	9.45	0.04	29.78	Quasi Peak	Supply	57.68	-27.9	Pass
6	3.645042	15.25	9.54	0.07	24.86	Quasi Peak	Supply	56	-31.14	Pass
7	0.150386	30.71	9.29	0.04	40.05	Average	Supply	55.98	-15.93	Pass
8	0.219619	29.79	9.4	0.04	39.23	Average	Supply	52.83	-13.6	Pass
9	2.539471	15.46	9.5	0.06	25.02	Average	Supply	46	-20.98	Pass
10	0.306409	19.22	9.44	0.04	28.7	Average	Supply	50.07	-21.37	Pass
11	0.408493	18.31	9.45	0.04	27.8	Average	Supply	47.68	-19.88	Pass
12	3.645042	13.6	9.54	0.07	23.22	Average	Supply	46	-22.78	Pass

Remarks:

1. The emission levels of other frequencies were very low against the limit.
2. Margin value = Emission level – Limit value
3. Correction factor = Insertion loss + Cable loss
4. Emission Level = Correction Factor + Reading Value

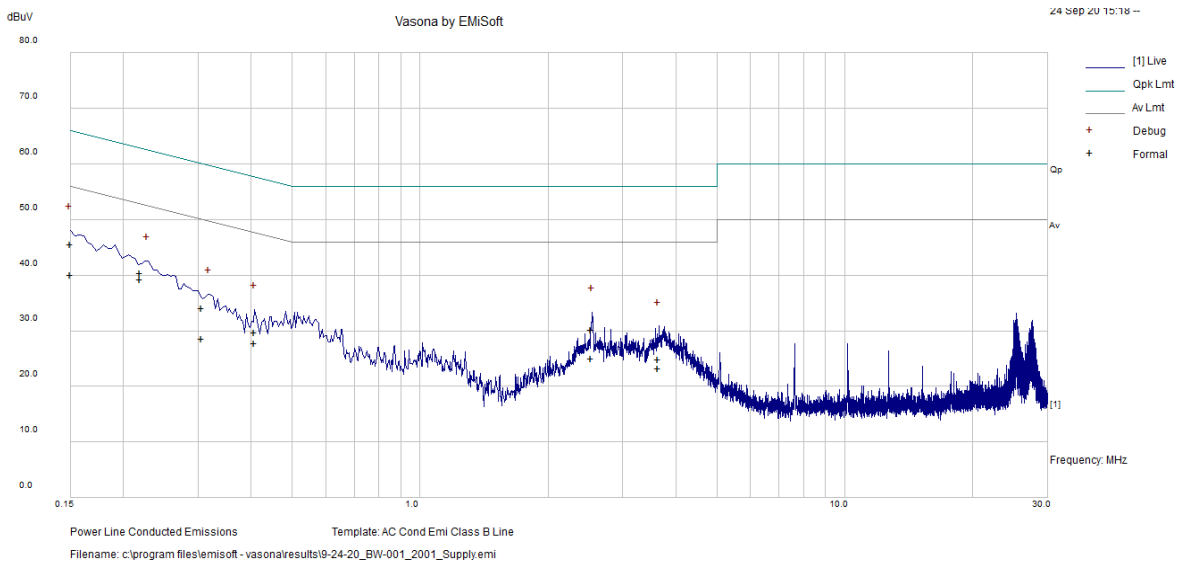

Frequency Range	0.15-30 MHz	Phase	Return
Input Power	5 Vdc	Environmental Conditions	23 °C, 49% RH
Tested by	Alok Patel	Test Date	9/24/2020
Test Mode	Normal Operation		

No	Frequency (MHz)	Reading Value (dBuV)	Cable Loss (dB)	Insertion Loss (dB)	Emission Level Corrected (dBuV)	Measurement Type	Supply/Return	Limit (dBuV)	Margin (dB)	Pass/Fail
1	0.15	36.15	9.29	0.03	45.47	Quasi Peak	Return	66	-20.53	Pass
2	0.227507	30.19	9.41	0.03	39.63	Quasi Peak	Return	62.54	-22.91	Pass
3	2.542731	19.25	9.5	0.05	28.8	Quasi Peak	Return	56	-27.2	Pass
4	0.531499	20.43	9.45	0.03	29.91	Quasi Peak	Return	56	-26.09	Pass
5	0.282806	26.25	9.44	0.03	35.71	Quasi Peak	Return	60.73	-25.02	Pass
6	0.634028	18.19	9.46	0.03	27.69	Quasi Peak	Return	56	-28.31	Pass
7	0.15	30.72	9.29	0.03	40.05	Average	Return	56	-15.95	Pass
8	0.227507	29.71	9.41	0.03	39.15	Average	Return	52.54	-13.39	Pass
9	2.542731	14.65	9.5	0.05	24.2	Average	Return	46	-21.8	Pass
10	0.531499	14.28	9.45	0.03	23.76	Average	Return	46	-22.24	Pass
11	0.282806	20.75	9.44	0.03	30.21	Average	Return	50.73	-20.52	Pass
12	0.634028	11.35	9.46	0.03	20.84	Average	Return	46	-25.16	Pass

Remarks:

1. The emission levels of other frequencies were very low against the limit.
2. Margin value = Emission level – Limit value
3. Correction factor = Insertion loss + Cable loss
4. Emission Level = Correction Factor + Reading Value

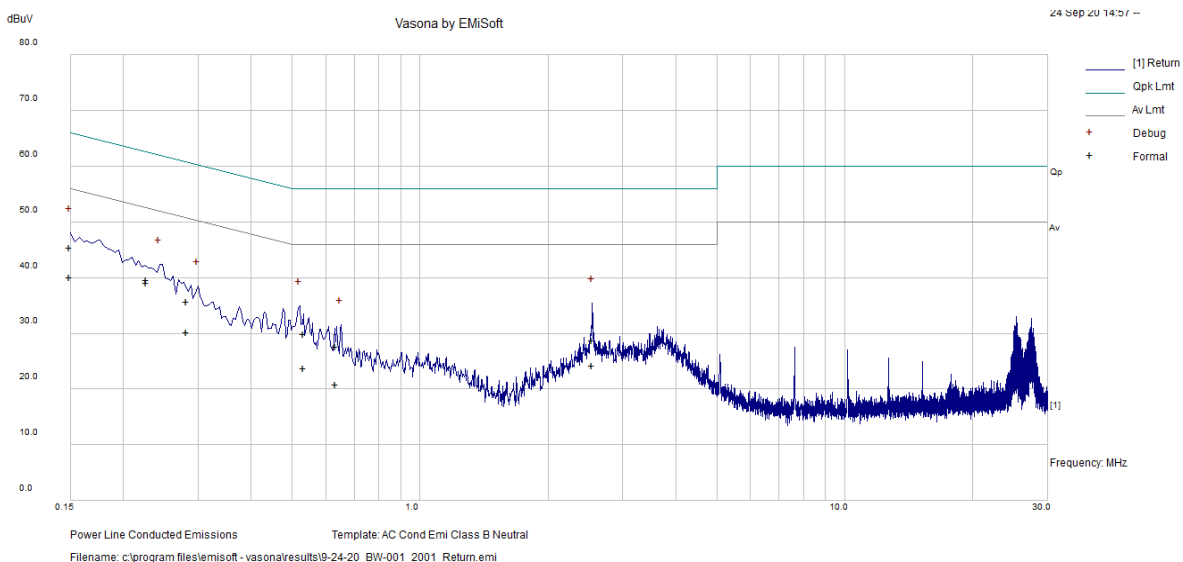



6 Conducted Disturbance at Telecommunication Ports

The test for the conducted disturbance at telecommunication ports is determined is not necessary for a EUT with no telecommunication port.



7 Radiated Disturbance up to 1 GHz

7.1 Limits

Frequency (MHz)	Class A (at 10m)	Class B (at 10m)
	dBuV/m	dBuV/m
30 - 230	40	30
230 - 1000	47	37

Frequency (MHz)	Class A (at 3m)	Class B (at 3m)
	dBuV/m	dBuV/m
30 - 230	50	40
230 - 1000	57	47

- Notes: 1. The lower limit shall apply at the transition frequencies.
2. Emission level (dBuV/m) = 20 log Emission level (uV/m).
3. All emanations from a class A/B digital device or system, including any network of conductors and apparatus connected thereto, shall not exceed the level of field strengths specified above.

7.2 Test Instruments

Description & Manufacturer	Model No.	Serial No.	Cal. Date	Cal. Due
EMI Receiver Keysight	N9038A	MY55330108	7/4/2020	7/4/2021
Biconilog Antenna Sunol	JB6	A111717	9/4/2020	9/4/2021
Pre-Amplifier RF Bay, Inc.	LPA-6-30	11170601	4/27/2020	4/27/2021

7.3 Test Arrangement

- The EUT was placed on the top of a rotating table 0.8 meters above the ground at an accredited test facility. The table was rotated 360 degrees to determine the position of the highest radiation.
- The EUT was set 10 meters away from the interference-receiving antenna, which was mounted on the top of a variable-height antenna tower.
- The antenna is a broadband antenna, and its height is varied from one meter to four meters above the ground to determine the maximum value of the field strength. Both horizontal and vertical polarizations of the antenna are set to make the measurement.
- For each suspected emission, the EUT was arranged to its worst case and then the antenna was tuned to heights from 1 meter to 4 meters and the rotatable table was turned from 0 degrees to 360 degrees to find the maximum reading.
- The test-receiver system was set to quasi-peak detect function and specified bandwidth with maximum hold mode when the test frequency is up to 1 GHz.

Note: The resolution bandwidth and video bandwidth of test receiver/spectrum analyzer is 120 kHz for quasi-peak detection (QP) at frequency up to 1GHz.

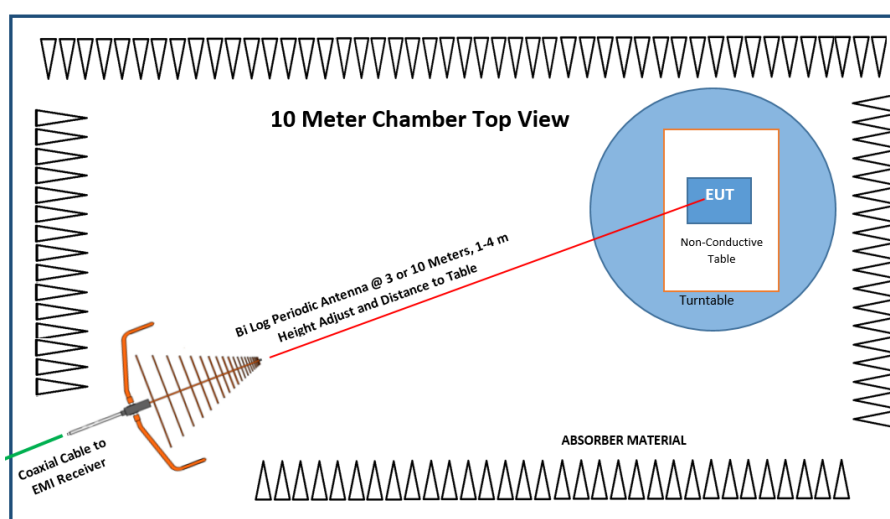

7.4 Test Results

Frequency Range	30-1000 MHz		
Input Power	5 Vdc	Environmental Conditions	23 °C, 45% RH
Tested by	Alok Patel	Test Date	9/27/2020
Test Mode	Normal Operation		

Antenna Polarity & Test Distance: Vertical and Horizontal at 10m										
No.	Frequency (MHz)	Polarization (H/V)	Reading QP [dB(uV)]	Factor [dB(1/m)]	Level QP [dB(uV/m)]	Limit\QP dB(uV/m)	Margin QP [dB]	Height (cm)	Angle (Deg)	Pass/Fail
1	30.961	H	37.8	-12.4	25.4	30	4.6	336	2.8	Pass
2	31.27	V	38	-13	25	30	5	108	295.1	Pass
3	45.362	V	46	-23.6	22.4	30	7.6	100	214.1	Pass
4	107.76	V	44.4	-23	21.4	30	8.6	104	39.7	Pass
5	112.461	V	47.9	-22.2	25.7	30	4.3	100	358.4	Pass
6	117.968	V	49.5	-22	27.5	30	2.5	100	62.5	Pass

Remarks:

1. Level (dBuV) = Reading (dBuV) + Factor (dB(1/m)).
2. Factor (dB(1/m)) = Antenna Factor(AF) (dB(1/m)) + Cable Loss (dB)
3. Margin = Limit value(dBuV/m) - Level (dBuV/m)

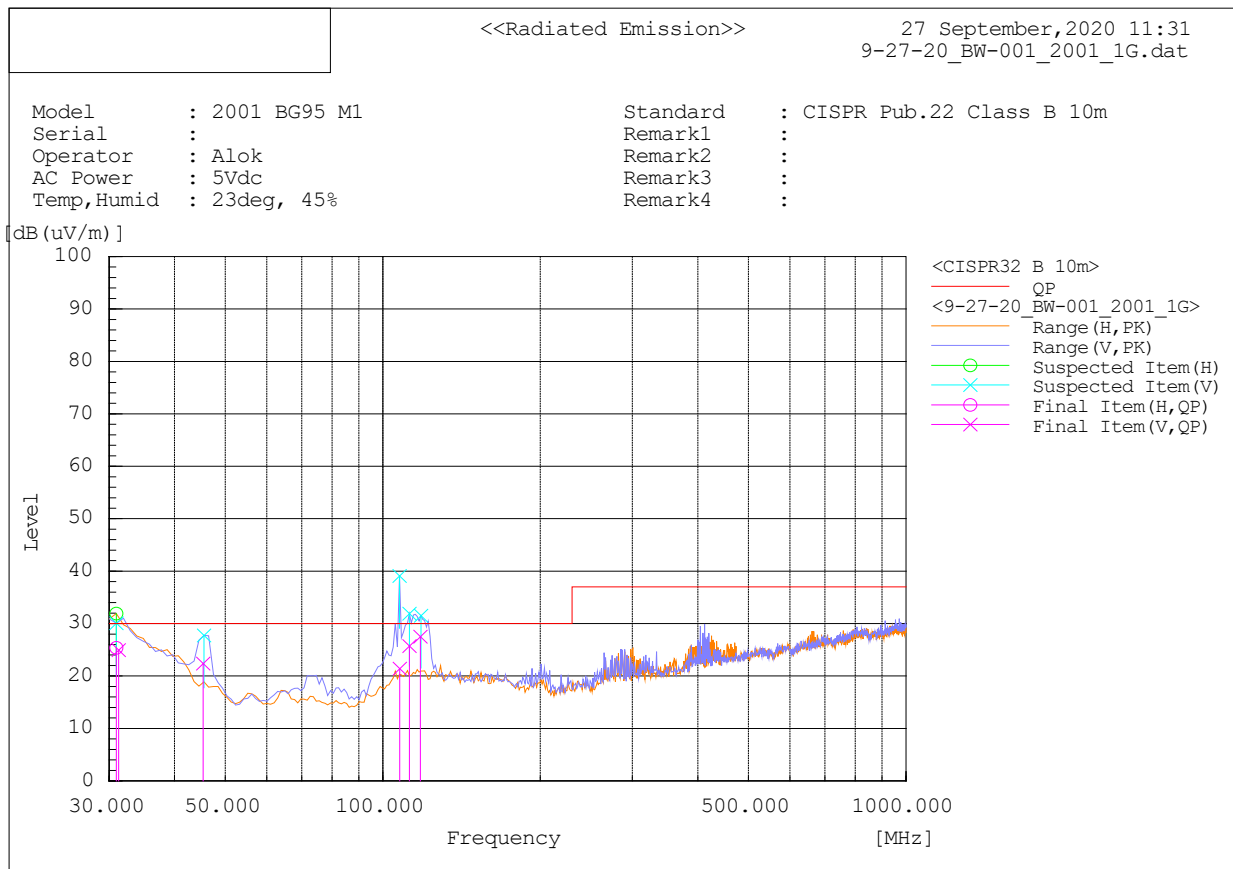

8 Radiated Disturbance above 1 GHz

8.1 Limits

Frequency (GHz)	Class A (dBuV/m) (at 3m)		Class B (dBuV/m) (at 3m)	
	Average	Peak	Average	Peak
1 to 3	56	76	50	70
3 to 6	60	80	54	74

- Notes: 1. The lower limit shall apply at the transition frequencies.
 2. Emission level (dBuV/m) = 20 log Emission level (uV/m).
 3. All emanations from a class A/B digital device or system, including any network of conductors and apparatus connected thereto, shall not exceed the level of field strengths specified above.

Frequency Range of Radiated Measurement (For unintentional radiators)

Highest frequency generated or used in the EUT or on which the EUT operates or tunes (MHz)	Upper frequency of measurement range (MHz)
Below 108	1000
108-500	2000
500-1000	5000
Above 1000	Up to 5 times of the highest frequency or 6 GHz, whichever is less

8.2 Test Instruments

Description & Manufacturer	Model No.	Serial No.	Cal. Date	Cal. Due
EMI Receiver Keysight	N9038A	MY55330108	7/4/2020	7/4/2021
Horn Antenna ETS-Lindgren	3117	218553	11/20/2019	11/20/2020
Pre-Amplifier RF-Lambda	RAMP00M50GA	17032300048	7/4/2020	7/4/2021

8.3 Test Arrangement

- The EUT was placed on the top of a rotating table 0.8 meters above the ground at an accredited chamber room. The table was rotated 360 degrees to determine the position of the highest radiation.
- The EUT was set 3 meters away from the interference-receiving antenna, which was mounted on the top of a variable-height antenna tower.
- The height of antenna can be varied from one meter to four meters, the height of adjustment depends on the EUT height and the antenna 3dB beamwidth both, to detect the maximum value of the field strength. Both horizontal and vertical polarizations of the antenna are set to make the measurement.
- For each suspected emission, the EUT was arranged to its worst case and then the antenna was tuned to heights and the rotatable table was turned from 0 degrees to 360 degrees to find the maximum reading.
- The spectrum analyzer system was set to peak and average detects function and specified bandwidth with maximum hold mode when the test frequency is above 1 GHz.

Note:

- The resolution bandwidth of test receiver/spectrum analyzer is 1MHz and video bandwidth is 3MHz for Peak detection (PK) at frequency above 1GHz. The resolution bandwidth of test receiver/spectrum analyzer is 1 MHz for Average detection (AV) at frequency above 1GHz.

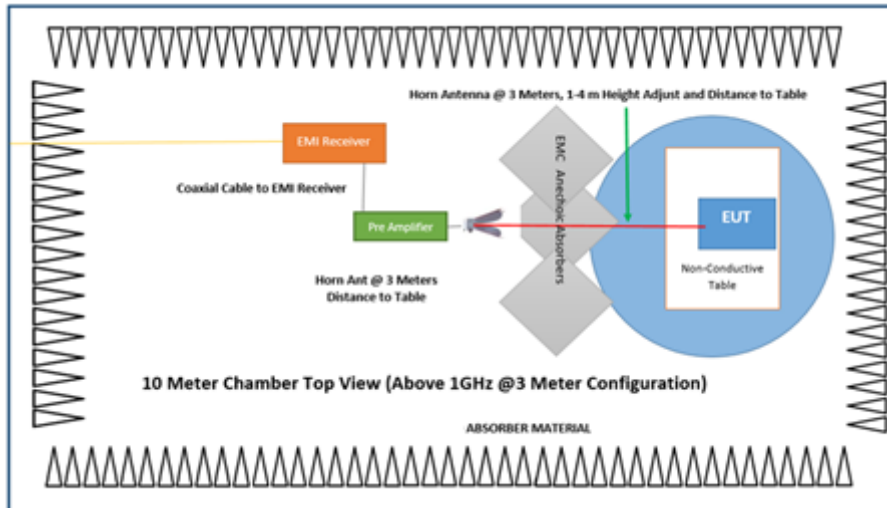



8.4 Test Results

Frequency Range	1000-6000 MHz		
Input Power	5 Vdc	Environmental Conditions	24 °C, 48% RH
Tested by	Alok Patel	Test Date	9/27/2020
Test Mode	Normal Operation		

Antenna Polarity & Test Distance: Vertical and Horizontal at 3m														
No.	Frequency (MHz)	Polarization (H/V)	Reading AV [dB(uV)]	Reading PK [dB(uV)]	Factor [dB(1/m)]	Level AV [dB(uV/m)]	Level PK [dB(uV/m)]	LimitAV [dB(uV/m)]	LimitPK [dB(uV/m)]	Margin AV [dB]	Margin PK [dB]	Height (cm)	Angle (Deg)	Pass/Fail
1	1985.465	H	39.5	53.3	-6	39.5	53.3	50	70	16.5	22.7	222	192	Pass
2	2002.841	V	39.5	52.5	-6	39.5	52.5	50	70	16.5	23.5	155	339	Pass

Remarks:

1. Level (dBuV) = Reading (dBuV) + Factor (dB(1/m)).
2. Factor (dB(1/m)) = Antenna Factor(AF) (dB(1/m)) + Cable Loss (dB) -Preamplifier Gain (dB)
3. Margin = Limit value(dBuV/m) - Level (dBuV/m)

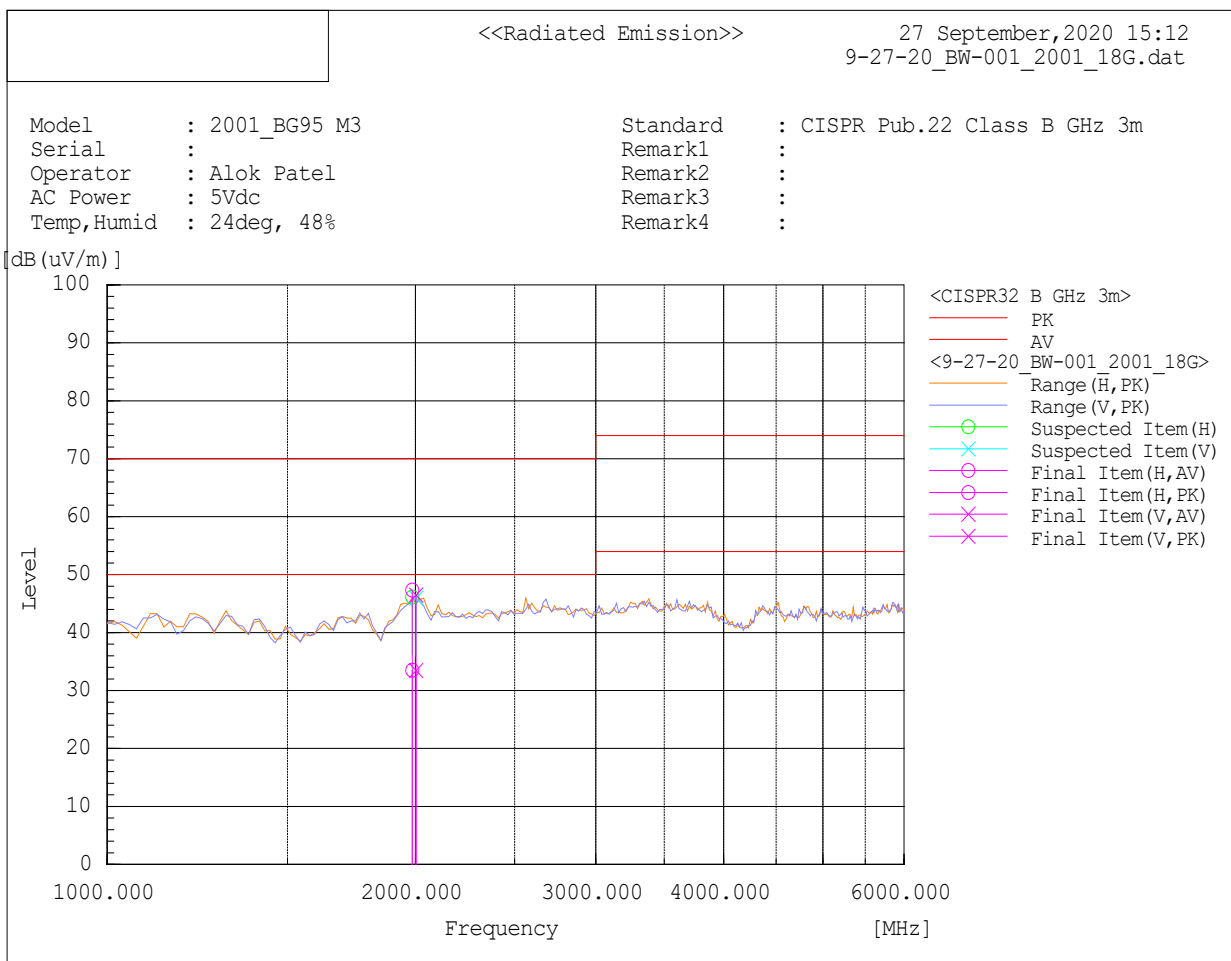

9 Harmonics Current Measurement

Test not applicable because the port does not exist.

10 Voltage Fluctuations and Flicker Measurement

Test not applicable because the port does not exist.

11 General Immunity requirements

EN 301 489 Series, Immunity requirements		
Reference standard	Test specification	Performance Criterion
EN 61000-4-3 RS	Enclosure port: 80% AM (1kHz) <ul style="list-style-type: none"> • 80-1000 MHz, 3V/m • 1800, 2600, 3500, 5000 MHz, 3V/m • 1000-6000 MHz, 3V/m • 690-6000 Mhz, 10V/m 	A
EN 61000-4-4 EFT	Signal ports, telecommunication ports and control ports: $\pm 0.5\text{kV}$, 5/50 T_r/T_h ns 5kHz Input DC power ports: $\pm 0.5\text{kV}$ 5/50 T_r/T_h ns, 5kHz	B
EN 61000-4-6 CS	<u>Signal ports, telecommunication ports, control ports and DC power ports(if cables length > 3m):</u> 0.15-80 MHz, 3V, 80% AM (1kHz) 0.15-10 MHz, 3V, 80% AM (1kHz) 10-30 MHz, 3V to 1V, 80% AM (1kHz) 30-80 MHz, 1V, 80% AM (1kHz)	A

11.1 Performance Criteria

General Performance Criteria for EN 55035

These criteria shall be used during the testing of primary functions where no relevant annex is applicable.

When assessing the impact of a disturbance on a function, the assessment should take into consideration the function's performance prior to the application of the disturbance and only identify as failures those changes in performance that are a result of the disturbance

Performance Criterion A

The equipment shall continue to operate as intended without operator intervention. No degradation of performance, loss of function or change of operating state is allowed below a performance level specified by the manufacturer when the equipment is used as intended. The performance level may be replaced by a permissible loss of performance. If the minimum performance level or the permissible performance loss is not specified by the manufacturer, then either of these may be derived from the product description and documentation, and by what the user may reasonably expect from the equipment if used as intended.

Performance Criterion B

During the application of the disturbance, degradation of performance is allowed. However, no unintended change of actual operating state or stored data is allowed to persist after the test. After the test, the equipment shall continue to operate as intended without operator intervention; no degradation of performance or loss of function is allowed, below a performance level specified by the manufacturer, when the equipment is used as intended. The performance level may be replaced by a permissible loss of performance. If the minimum performance level (or the permissible performance loss), or recovery time, is not specified by the manufacturer, then either of these may be derived from the product description and documentation, and by what the user may reasonably expect from the equipment if used as intended.

Performance Criterion C

Loss of function is allowed, provided the function is self-recoverable, or can be restored by the operation of the controls by the user in accordance with the manufacturer's instructions. A reboot or re-start operation is allowed. Information stored in non-volatile memory, or protected by a battery backup, shall not be lost.

General Performance Criteria For 301 489 series

- Performance criteria for continuous phenomena applied to transmitters and receivers (CT/CR)

During and after the test, the apparatus shall continue to operate as intended. No degradation of performance or loss of function is allowed below a permissible performance level specified by the manufacturer when the apparatus is used as intended. In some cases this permissible performance level may be replaced by a permissible loss of performance.

During the test the EUT shall not unintentionally transmit or change its actual operating state and stored data.

If the minimum performance level or the permissible performance loss is not specified by the manufacturer, then either of these may be deduced from the product description and documentation and what the user may reasonably expect from the apparatus if used as intended.

- Performance criteria for transient phenomena applied to transmitters and receivers (TT/TR)

After the test, the apparatus shall continue to operate as intended. No degradation of performance or loss of function is allowed below a permissible performance level specified by the manufacturer, when the apparatus is used as intended. In some cases this permissible performance level may be replaced by a permissible loss of performance.

During the EMC exposure to an electromagnetic phenomenon, a degradation of performance is, however, allowed. No change of the actual mode of operation (e.g. unintended transmission) or stored data is allowed.

If the minimum performance level or the permissible performance loss is not specified by the manufacturer, then either of these may be deduced from the product description and documentation and what the user may reasonably expect from the apparatus if used as intended.

- Performance criteria for equipment which does not provide a continuous communication link

For radio equipment which does not provide a continuous communication link, the performance criteria described in CT/CR and TT/TR are not appropriate, then the manufacturer shall declare, for inclusion in the test report, his own specification for an acceptable level of performance or degradation of performance during and/or after the immunity tests.

The performance criteria specified by the manufacturer shall give the same degree of immunity protection as called for in CT/CR and TT/TR.

- Performance criteria for ancillary equipment tested on a stand alone basis

If ancillary equipment is intended to be tested on a stand alone basis, the performance criteria described in CT/CR and TT/TR are not appropriate, then the manufacturer shall declare, for inclusion in the test report, his own specification for an acceptable level of performance or degradation of performance during and/or after the immunity tests.

The performance criteria specified by the manufacturer shall give the same degree of immunity protection as called for in CT/CR and TT/TR.

Product Specific Performance Criteria

The particular performance criteria which are specified in the relevant part of EN 301 489 series dealing with the particular type of radio equipment, take precedence over the corresponding parts of the general performance criteria.

Where particular performance criteria for specific functions are not given, then the general performance criteria shall apply.

EN 301 489-50, Specific conditions Cellular Communication Base Station (BS), repeater and ancillary equipment

Performance criteria for continuous phenomena applied to Base Stations and Repeaters

UTRA:

The BLER calculation shall be based on evaluating the CRC on each transport block.

During immunity tests of the BS Uplink and Downlink paths the observed BLER shall be less than 1×10^{-2} and the BS shall operate as intended. If the Uplink and Downlink paths are evaluated as one loop then the criteria is less than 2×10^{-2} .

After each test case the BS shall operate as intended with no loss of user control functions or stored data, the communications link shall be maintained.

E-UTRA:

The test should, where possible, be performed using a bearer with the characteristics of data rate and throughput defined in the below table. If the test is not performed using one of these bearers (for example, if none of them are supported by the BS), the characteristics of the bearer used shall be recorded in the test report.

The throughput in table 4 is stated relative to the maximum throughput of the FRC. The maximum throughput for an FRC is equal to the payload size \times the number of uplink sub-frames per second.

The BS Uplink and Downlink paths shall each meet the performance criteria defined in table 4 during the test. If the Uplink and Downlink paths are evaluated as a one loop then the criteria is two times the throughput reduction shown in table 4. After each test case BS shall operate as intended with no loss of user control function, stored data and the communication link shall be maintained.

BS Performance Criteria for continuous phenomena for BS

E-UTRA Channel Bandwidth [MHz]	Bearer Information Data Rate	Performance Criteria (see notes 1 and 2)
1.4	FRC A1-1 in clause A.1 In ETSI TS 136 104 [5]	Throughput > 95 % No loss of service
3	FRC A1-1 in clause A.1 In ETSI TS 136 104 [5]	Throughput > 95 % No loss of service
5	FRC A1-1 in clause A.1 In ETSI TS 136 104 [5]	Throughput > 95 % No loss of service
10	FRC A1-1 in clause A.1 In ETSI TS 136 104 [5] (see note 3)	Throughput > 95 % No loss of service
15	FRC A1-1 in clause A.1 In ETSI TS 136 104 [5] (see note 3)	Throughput > 95 % No loss of service
20	FRC A1-1 in clause A.1 In ETSI TS 136 104 [5] (see note 3)	Throughput > 95 % No loss of service

NOTE 1: The performance criteria, Throughput > 95 % / No loss of service, applies also if a bearer with another characteristics is used in the test.

NOTE 2: The performance criteria, Throughput > 90 % / No loss of service, applies instead if the Uplink and Downlink paths are evaluated as a one loop.

NOTE 3: This is the information data rate of a single instance of the bearer mapped to 25 resource blocks. The performance criteria shall be met for each consecutive application of a single instance of the bearer mapped to disjoint frequency ranges with a width of 25 resource blocks each.

After each test case the BS shall operate as intended with no loss of user control functions or stored data. The communications link shall be maintained

EN 301 489-50, Specific conditions Cellular Communication Base Station (BS), repeater and ancillary equipment (continued)

GSM/EDGE

Downlink

The BER of the downlink shall be assessed during the test according to one of the test methods of clause 5.2.1 in the present document.

If the test method of clause 5.2.1.1 in the present document is used, the measured BER of the class 2 bits of TCH/FS shall not exceed 1,6 % during the test.

NOTE 1: This BER is the upper limit in ETSI TS 145 008 [7], clause 8.2.4 for RXQUAL = 3.

If the test method of clause 5.2.1.2 in the present document is used, the value of RXQUAL shall not exceed 3 during the test.

At the conclusion of the test the EUT shall operate as intended with no loss of user control functions or stored data, and the communication link shall have been maintained.

Uplink

The BER of the uplink shall be assessed during the test according to one of the test methods of clause 5.2.2 in the present document.

If the test method of clause 5.2.2.1 in the present document is used, the value of RXQUAL shall not exceed 3 during the test.

If the test method of clause 5.2.2.2 in the present document is used, the measured BER of the class 2 bits of TCH/FS shall not exceed 1,6 % during the test.

NOTE 2: This BER is the upper limit in ETSI TS 145 008 [7], clause 8.2.4 for RXQUAL = 3.

For a base station the RXQUAL of the uplink shall not exceed three (3) measured during the test sequence.

At the conclusion of the test the EUT shall operate as intended with no loss of user control functions or stored data, and the communication link shall have been maintained.

CDMA

During the immunity test, the observed Frame Error Rate (FER) of the BS forward link and reverse link shall not exceed 1,0 % with 95 % confidence (see clause 6.8 in TIA-97 [18]), and the BS shall operate as intended. However, in the case of PAMR base stations the observed Frame Error Rate (FER) of the BS forward link and reverse link shall not exceed 2,0 % with 95 % confidence (see clause 6.8 in TIA-97 [18]), and the BS shall operate as intended.

Mobile OFDMA WMAN

Mobile OFDMA WMAN Channel Bandwidth [MHz]	Performance Criteria (see notes 1 and 2)
5	Throughput > 95 % No loss of service
10	Throughput > 95 % No loss of service
Note 1: The performance criteria, Throughput > 95% / No loss of service, applies also if a bearer with another characteristics is used in the test.	
Note 2: The performance criteria, Throughput > 90% / No loss of service, applies instead if the Uplink and Downlink paths are evaluated as a one loop	

After each test case, the BS shall operate as intended with no loss of user control function, or stored data, the communication link shall be maintained.

EN 301 489-50, Specific conditions Cellular Communication Base Station (BS), repeater and ancillary equipment (continued)**Repeaters**

The RF gain of the EUT shall be measured throughout the period of exposure to the phenomenon. The RF gain measured during the test shall not deviate from the gain measured before the test by more than ± 1 dB.

At the conclusion of the test the EUT shall operate as intended with no loss of user control functions or stored data.

Performance criteria for transient phenomena for Base Station and RepeatersBase stations (BS)

At the conclusion of each exposure the EUT shall operate with no user noticeable loss of the communication link.

At the conclusion of the total test comprising the series of individual exposures the EUT shall operate as intended with no loss of user control functions or stored data, as declared by the manufacturer, and the communication link shall have been maintained.

Repeaters

The RF gain of the EUT shall be measured before the test and after each exposure. At the conclusion of each exposure the gain of the EUT shall not have changed by more than ± 1 dB. At the conclusion of the total test comprising the series of individual exposures, the EUT shall operate as intended with no loss of user control functions or stored data, as declared by the manufacturer, and the gain of the EUT shall not have changed by more than ± 1 dB.

Performance criteria for ancillary equipment tested on a standalone basisPerformance criteria for continuous phenomena for ancillary equipment

The EUT shall continue to operate as intended during and after the test. No degradation of performance or loss of function is allowed below the performance level specified by the manufacturer, when the apparatus is used as intended.

The performance level may be replaced by a permissible performance loss. If the minimum performance level or the permissible performance loss is not specified by the manufacturer, either of these may be derived from the product description and documentation and what the user may reasonably expect from the apparatus if used as intended.

Performance criteria for transient phenomena for ancillary equipment

The EUT shall continue to operate as intended after the test. No degradation of performance or loss of function is allowed below the performance level specified by the manufacturer, when the apparatus is used as intended. The performance level may be replaced by a permissible performance loss. During the test, degradation of performance is however allowed. If the minimum performance level or the permissible performance loss is not specified by the manufacturer, either of these may be derived from the product description and documentation and what the user may reasonably expect from the apparatus if used as intended.

EN 301 489-52, Specific conditions Cellular Communication Mobile and portable (UE) radio

GSM and DCS General Criteria

The establishment and maintenance of a communications link, the assessment of RXQUAL, and the assessment of the audio breakthrough by monitoring the speech output signal level, are used as performance criteria to ensure that all primary functions of the transmitter and receiver are evaluated during the immunity tests. In addition, the test shall also be performed in idle mode to ensure the transmitter does not unintentionally operate.

The maintenance of a communications link shall be assessed using an indicator which may be part of the test system or the EUT.

If an equipment is of a specialized nature, such that the performance criteria described in the following clauses are not appropriate, then the manufacturer shall declare, for inclusion in the test report, his own specification for an acceptable level of performance or degradation of performance during and/or after the immunity tests. The performance specification shall be included in the product description and documentation.

The performance criteria specified by the manufacturer shall give the same degree of immunity protection as called for in the following clauses.

GSM and DCS Performance criteria for Continuous phenomena applied to Transmitters (CT)

A communication link shall be established at the start of the test, and maintained during the test

During the test, the uplink speech output level shall be at least 35 dB less than the previously recorded reference levels, when measured through an audio band pass filter of width 200 Hz, centred on 1 kHz (audio breakthrough check).

NOTE: When there is a high level background noise present the filter bandwidth can be reduced down to a minimum of 40 Hz.

At the conclusion of the test, the EUT shall operate as intended with no loss of user control functions or stored data, and the communication link shall have been maintained. In addition to confirming the above performance during a call, the test shall also be performed in idle mode, and the transmitter shall not unintentionally operate.

GSM and DCS Performance criteria for Transient phenomena applied to Transmitters (TT)

A communications link shall be established at the start of the test

At the conclusion of each exposure the EUT shall operate with no user noticeable loss of the communication link.

At the conclusion of the total test comprising the series of individual exposures, the EUT shall operate as intended with no loss of user control functions or stored data, as declared by the manufacturer, and the communication link shall have been maintained.

In addition to confirming the above performance during a call, the test shall also be performed in idle mode, and the transmitter shall not unintentionally operate.

GSM and DCS Performance criteria for Continuous phenomena applied to Receivers (CR)

A communications link shall be established at the start of the test

During the test, the RXQUAL of the downlink shall not exceed the value of three, measured during each individual exposure in the test sequence.

During the test, the downlink speech output level shall be at least 35 dB less than the previously recorded reference levels, when measured through an audio band pass filter of width 200 Hz, centred on 1 kHz (audio breakthrough check).

NOTE: When there is a high level background noise present the filter bandwidth can be reduced down to a minimum of 40 Hz.

At the conclusion of the test, the EUT shall operate as intended with no loss of user control functions or stored data, and the communication link shall have been maintained.

EN 301 489-52, Specific conditions Cellular Communication Mobile and portable (UE) radio GSM and DCS Performance criteria for Transient phenomena applied to Receivers (TR)

A communications link shall be established at the start of the test. At the conclusion of each exposure the EUT shall operate with no user noticeable loss of the communication link.

At the conclusion of the total test comprising the series of individual exposures, the EUT shall operate as intended with no loss of user control functions or stored data, as declared by the manufacturer, and the communication link shall have been maintained.

CDMA Direct Spread (UTRA and E-UTRA) General Criteria

The maintenance of a communications link shall be assessed by using an indicator, which may be part of the test system or the equipment under test.

If an equipment is of a specialized nature, that the performance criteria described in the following clauses are not appropriate, then the manufacturer shall declare, for inclusion in the test report, his own specification for an acceptable level of performance or degradation of performance during and/or after testing, as required by the present document.

The performance criteria specified by the manufacturer shall give the same degree of immunity protection as called for in the following clauses.

In addition, the test shall also be performed in idle mode to ensure the transmitter does not unintentionally operate.

The requirements apply to all types of UTRA and E-UTRA (FDD or TDD) for the UE.

CDMA Direct Spread (UTRA and E-UTRA) Continuous Phenomena General

A communication link shall be established at the start of the test, and maintained during the test, clauses 4.1 and 4.2.

In the speech mode, the performance criteria shall be that the Up Link and Down Link speech output levels shall be at least 35 dB less than the recorded reference levels, when measured through an audio band pass filter of width 200 Hz, centred on 1 kHz (annex B).

NOTE: When there is a high level of background audio noise present, the filter bandwidth can be reduced down to a minimum of 40 Hz.

At the conclusion of the test, the EUT shall operate as intended with no loss of user control functions or stored data, and the communication link shall have been maintained.

In addition to confirming the above performance in traffic mode, the test shall be performed in idle mode, and the transmitter shall not unintentionally operate.

UTRA Continuous Phenomena General

In the data transfer mode, the performance criteria can be one of the following:

- if the BER (as referred in ETSI TS 134 109 [4]) is used, it shall not exceed 0,001 during the test sequence;
- if the BLER (as referred in ETSI TS 134 109 [4]) is used, it shall not exceed 0,01 during the test sequence.

The BLER calculation shall be based on evaluating the CRC on each transport block.

E-UTRA Continuous Phenomena General

In the data transfer mode, the performance criteria shall be that the throughput shall be ≥ 95 % of the maximum throughput of the reference measurement channel as specified in annex C in ETSI TS 136 101 [9] with parameters specified in tables 7.3.1-1 and 7.3.1-2 in ETSI TS 136 101 [9] during the test sequence.

CDMA Direct Spread (UTRA and E-UTRA) Transient Phenomena General

At the conclusion of each exposure the EUT shall operate with no user noticeable loss of the communication link.

At the conclusion of the total test comprising the series of individual exposures, the EUT shall operate as intended with no loss of user control functions or stored data, as declared by the manufacturer, and the communication link shall have been maintained. In addition to confirming the above performance in traffic mode, the test shall also be performed in idle mode, and the transmitter shall not unintentionally operate.



12 Electrostatic Discharge Immunity Test (ESD)

This test is not applicable since EUT is internal component used inside of other devices.

13 Radiated, Radio-frequency, Electromagnetic Field Immunity Test (RS)

13.1 Test Specification

Basic Standard:	EN 61000-4-3
Frequency Range:	80 MHz ~ 6000 MHz***
Field Strength:	3 V/m to 10 V/m***
Modulation:	1kHz or 2kHz Sine Wave, 80%, AM Modulation***
Frequency Step:	1 % of preceding frequency value
Polarity of Antenna:	Horizontal and Vertical
Antenna Height:	1.5m
Dwell Time:	3 seconds

***Test levels vary based on test standard see test arrangement section or test result section for specific test values

13.2 Test Instruments

Description & Manufacturer	Model No.	Serial No.	Cal. Date	Cal. Due
Signal Generator (0.1-6000MHz) Agilent	N5182A	MY47071065	8/15/2020	8/15/2021
EMC Field Probe ETS-Lindgren	HI-6005	156327	3/25/2020	3/25/2021
250 Watt Amplifier (80-1000 MHz) Amplifier Research	250W1000C	353461	N/A	N/A
RF Power Amplifier (700-6000 MHz) Ophir RF Inc.	5293RE	1035	N/A	N/A
Biconilog Antenna (26 MHz – 2GHz) EMCO	3141	1203	N/A	N/A
Horn Antenna (700 MHZ – 18 GHz)	SAS-571	411	N/A	N/A
Power Meter Teseq, Inc.	PM 6006	77343	2/6/2020	2/6/2021

13.3 Test Arrangement

The test procedure was in accordance with EN 61000-4-3.

- The testing was performed in a semi anechoic chamber.
- The frequency range is swept from 80 MHz to 6000 MHz with The signal was 80% amplitude modulated
- The field strength level was 3V/m or 10V/m.
- The test was performed with the EUT exposed to both vertically and horizontally polarized fields on each of the four sides.

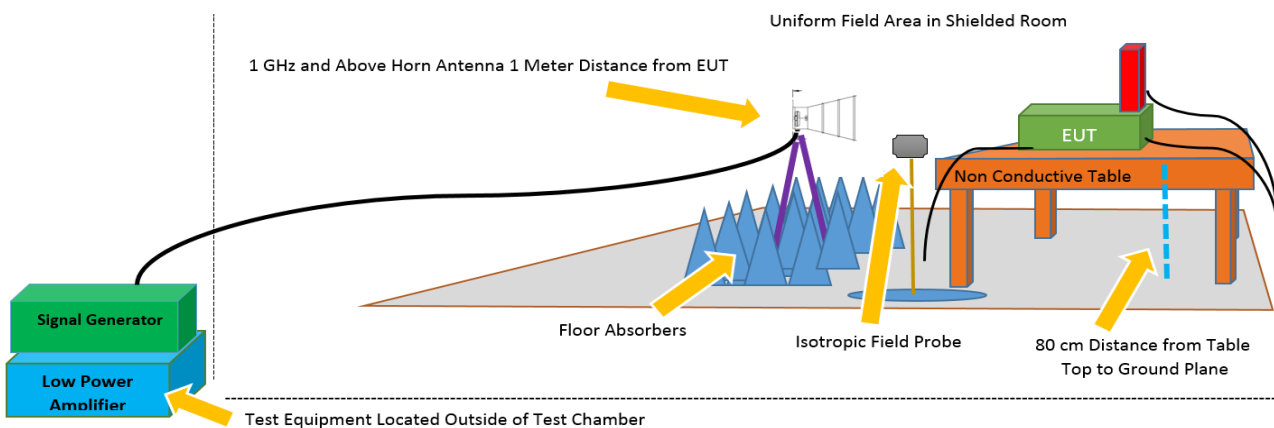
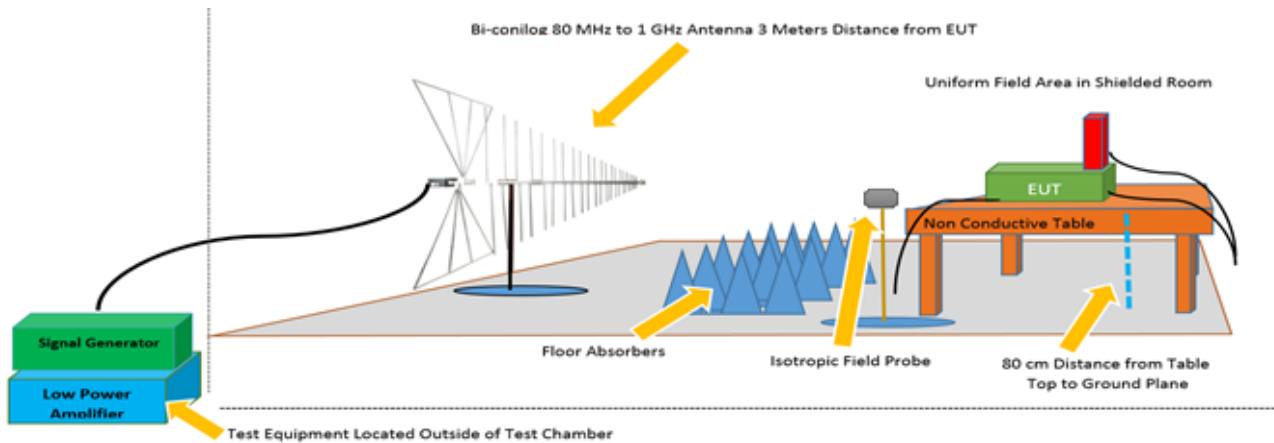



13.4 Test Results

Input Power	5 Vdc	Tested by	Alok Patel
Environmental conditions	25 °C, 48% RH	Test Date	9/28/2020
Test mode	Normal Operation		

Frequency (MHz)	Polarity	Azimuth(°)	Applied Field Strength		Observation	Remarks	Performance Criterion
			(V/m)	Modulation			
80 - 1000	V&H	0, 90, 180, 270	3	80% AM (1kHz)	Note 1	-	A
1800, 2600, 3500, 5000	V&H	0, 90, 180, 270	3	80% AM (1kHz)	Note 1	-	A
1000 - 6000	V&H	0, 90, 180, 270	3	80% AM (1kHz)	Note 1	-	A
690 - 6000	V&H	0, 90, 180, 270	10	80% AM (1kHz)	Note 1	-	A

Note: 1. The EUT showed no susceptibility during testing

14 Electrical Fast Transient/Burst Immunity Test (EFT)

14.1 Test Specification

Basic Standard:	EN 61000-4-4
Test Voltage:	Signal ports, telecommunication and control ports: $\pm 0.5\text{kV}$ Input DC power port: $\pm 0.5\text{kV}$ Input AC Power ports: $\pm 1\text{kV}$
Impulse Repetition Frequency:	5kHz
Impulse Wave shape :	5/50 T_r/T_h ns
Burst Duration:	15 ms for 5kHz Repetition Frequency
Burst Period:	300 ms
Test Duration:	1 min.

14.2 Test Instruments

Description & Manufacturer	Model No.	Serial No.	Cal. Date	Cal. Due
Immunity Test System EMC-Partner	IMU3000 F5-S6-D	105684-2032	5/29/2020	5/29/2021
Capacitive Coupling Clamp EMC-Partner	CN-EFT1000	103468-1736	5/28/2020	5/28/2021

14.3 Test Arrangement

- Both positive and negative polarity discharges were applied.
- The distance between any coupling devices and the EUT should be 0.5 m for table-top equipment testing, and 1.0 m for floor standing equipment.
- The duration time of each test sequential was 1 minute.
- The transient/burst waveform was in accordance with EN 61000-4-4, 5/50 ns.

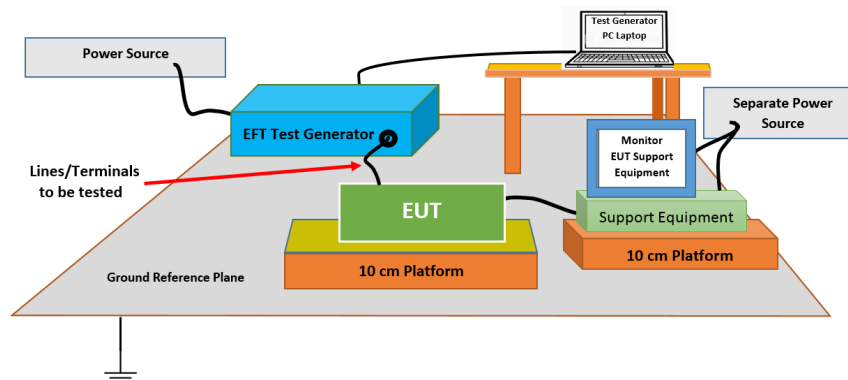

14.4 Test Results

Input Power	5 Vdc	Tested by	Alok Patel
Environmental conditions	24 °C, 48% RH	Test Date	9/30/3030
Test mode	Normal Operation		

Input power port

Voltage (kV)	Test Point	Polarity (+/-)	Observation	Performance Criterion
0.5	L1	+/-	Note 1	B
0.5	L2	+/-	Note 1	B
0.5	L1-L2	+/-	Note 1	B

Note: 1. The EUT showed no susceptibility during testing

15 Surge Immunity Test

This test not applicable since EUT does not have AC power port.

16 Immunity to Conducted Disturbances Induced by RF Fields (CS)

16.1 Test Specification

***Test levels vary based on test standard, see test arrangement section or test result section for specific test values if no special values are specified, the below values are used

Basic Standard:	EN 61000-4-6
Frequency Range:	0.15 MHz - 80 MHz
Voltage Level:	3V to 10V***
Modulation:	1kHz Sine Wave, 80%, AM Modulation***
Frequency Step:	1 % of preceding frequency value
Dwell Time	3 seconds

16.2 Test Instruments

Description & Manufacturer	Model No.	Serial No.	Cal. Date	Cal. Due
150 Watt Amplifier (10 KHz- 100 MHz) Amplifier Research	150A100D	353606	N/A	N/A
RF Signal Generator (100kHz-2100MHz) Fluke	6062A	5285403	12/05/2019	12/05/2020
Power Line CDN M2 Compower	M225E	34070020	1/14/2020	1/14/2021

16.3 Test Arrangement

- The EUT shall be tested within its intended operating and climatic conditions.
- An artificial hand was placed on the hand-held accessory and connected to the ground reference plane.
- One of the CDNs not used for injection was terminated with 50 ohm, providing only one return path. All other CDNs were coupled as decoupling networks.
- The frequency range is swept from 150 kHz to 80 MHz, using the signal level established during the setting process and with a disturbance signal of 80 % amplitude. The signal is modulated with a 1 kHz sine wave, pausing to adjust the RF signal level or the switch coupling devices as necessary. Where the frequency is swept incrementally, the step size shall not exceed 1 % of the preceding frequency value.
- Attempts should be made to fully exercise the EUT during testing, and to fully interrogate all exercise modes selected for susceptibility.

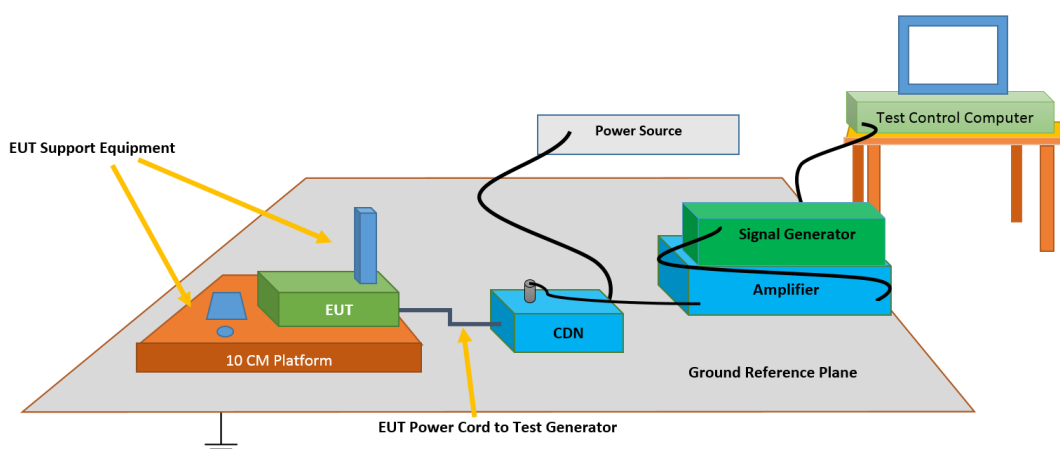



16.4 Test Results

Input Power	5 Vdc	Tested by	Alok Patel
Environmental conditions	22 °C, 50% RH	Test Date	9/24/2020
Test mode	Normal Operation		

Frequency (MHz)	Level (V rms)	Tested Line	Injection Method	Observation	Remark	Performance Criterion
0.15 – 80	3	DC power port	CDN-M2	Note 1	-	A

Note: 1. The EUT showed no susceptibility during testing



17 Power Frequency Magnetic Field

This test not applicable because the EUT does not contain components inherently susceptible to magnetic fields

18 Voltage Dips and Interruptions

This test not applicable since EUT does not have AC power port.

19 Pictures of Test Arrangements

19.1 EUT Photos

EUT External Photo 1

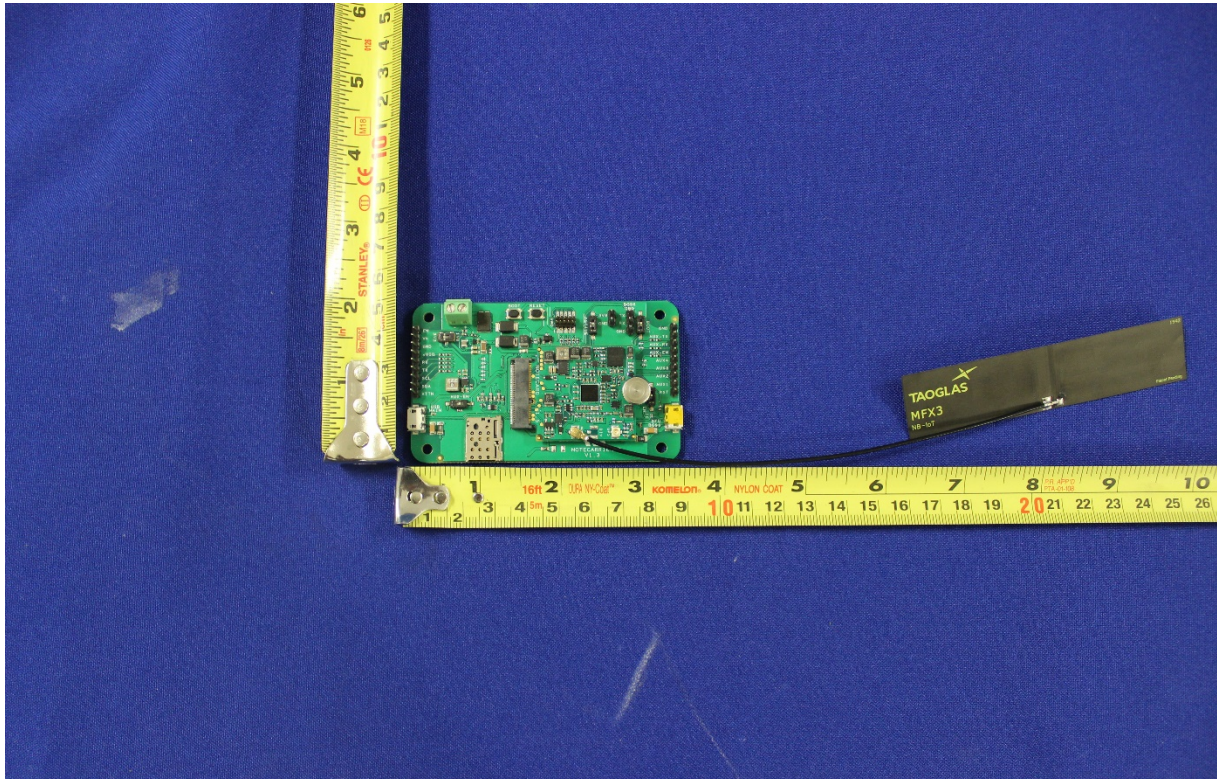

EUT External Photo 2

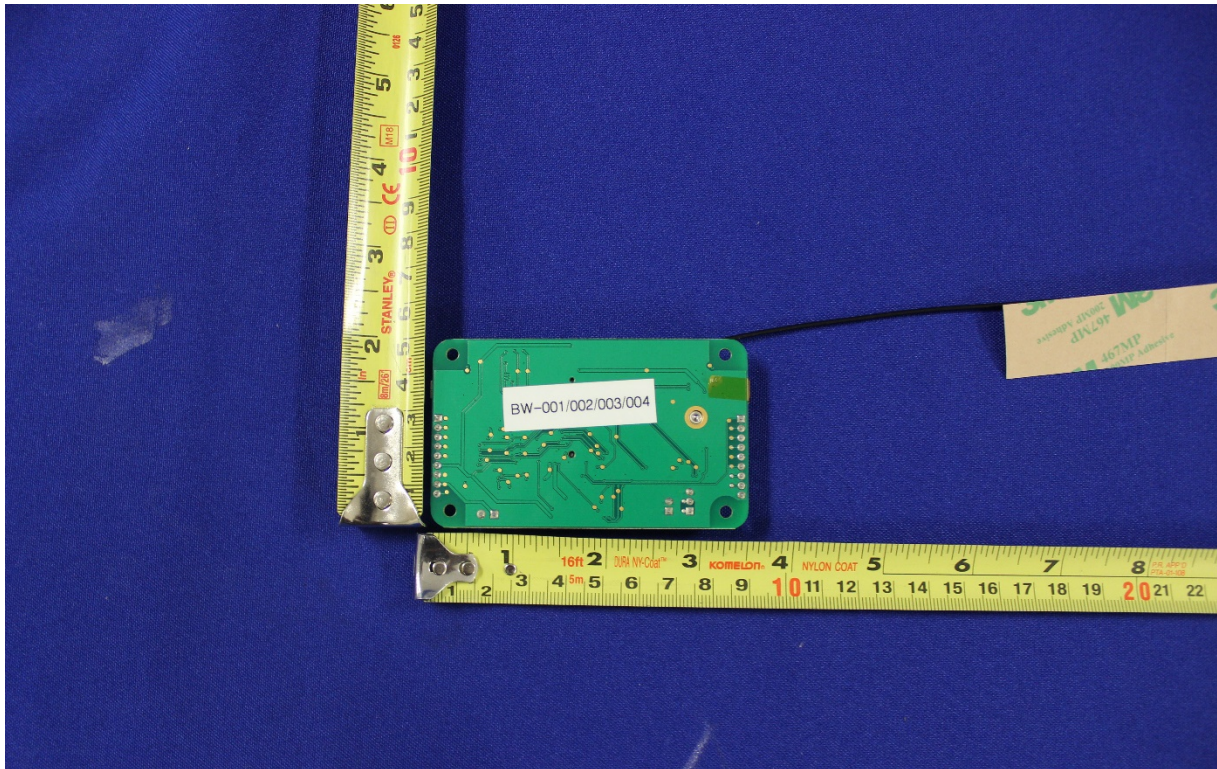

19.2 Conducted Emission from the DC Mains Power Port

Setup Front



Setup Rear

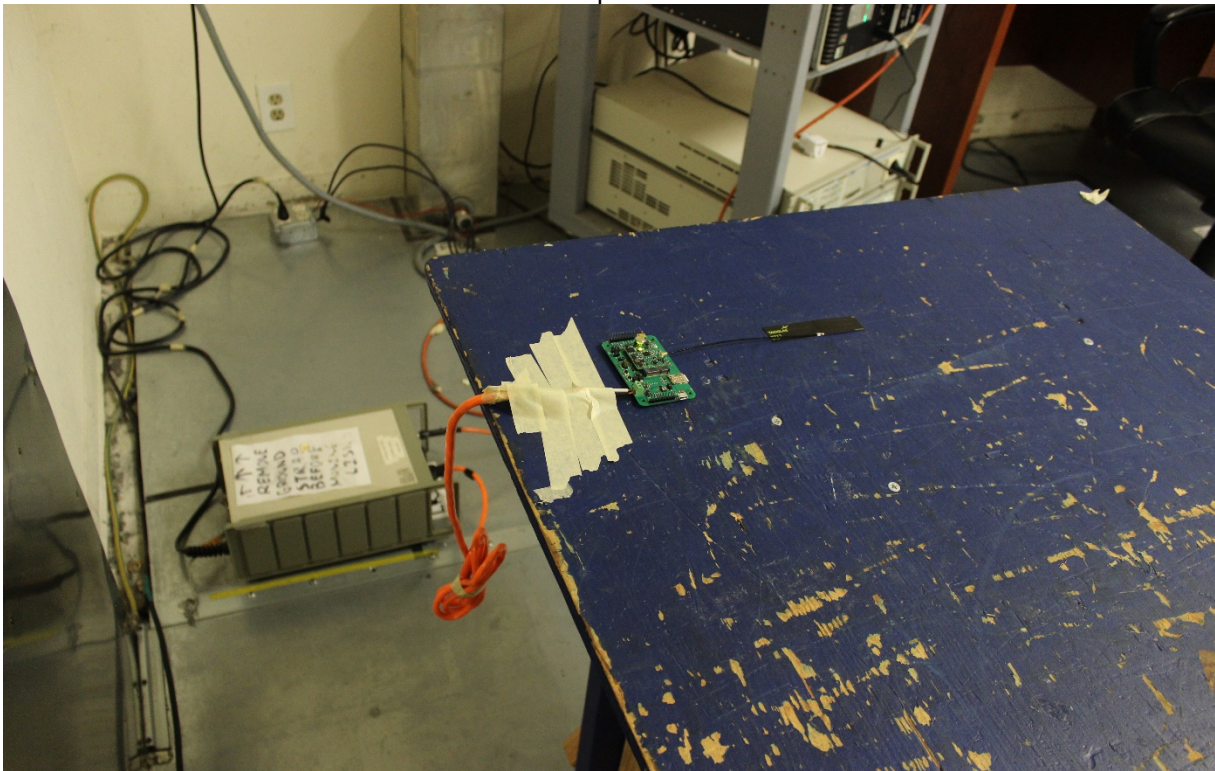

19.3 Radiated Emission at Frequencies up to 1GHz

Setup Front



Setup Rear

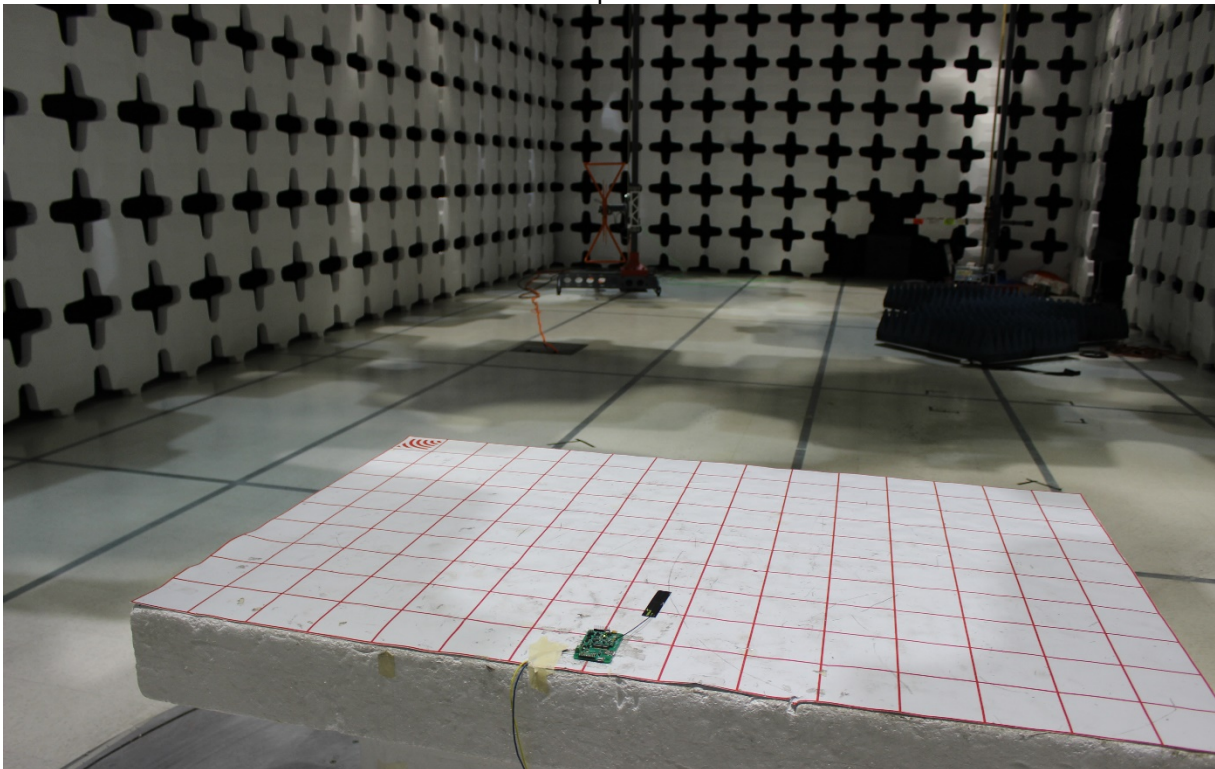

19.4 Radiated Emission at Frequencies above 1GHz

Setup Front

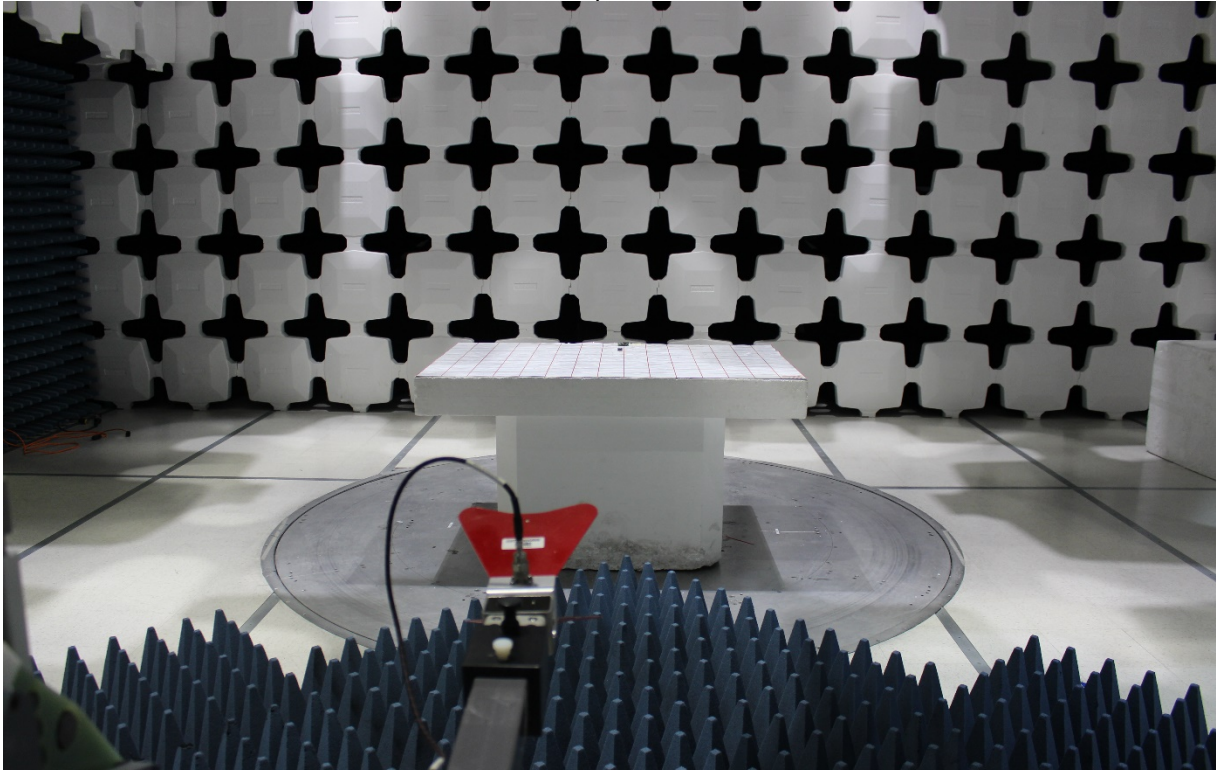

Setup Rear

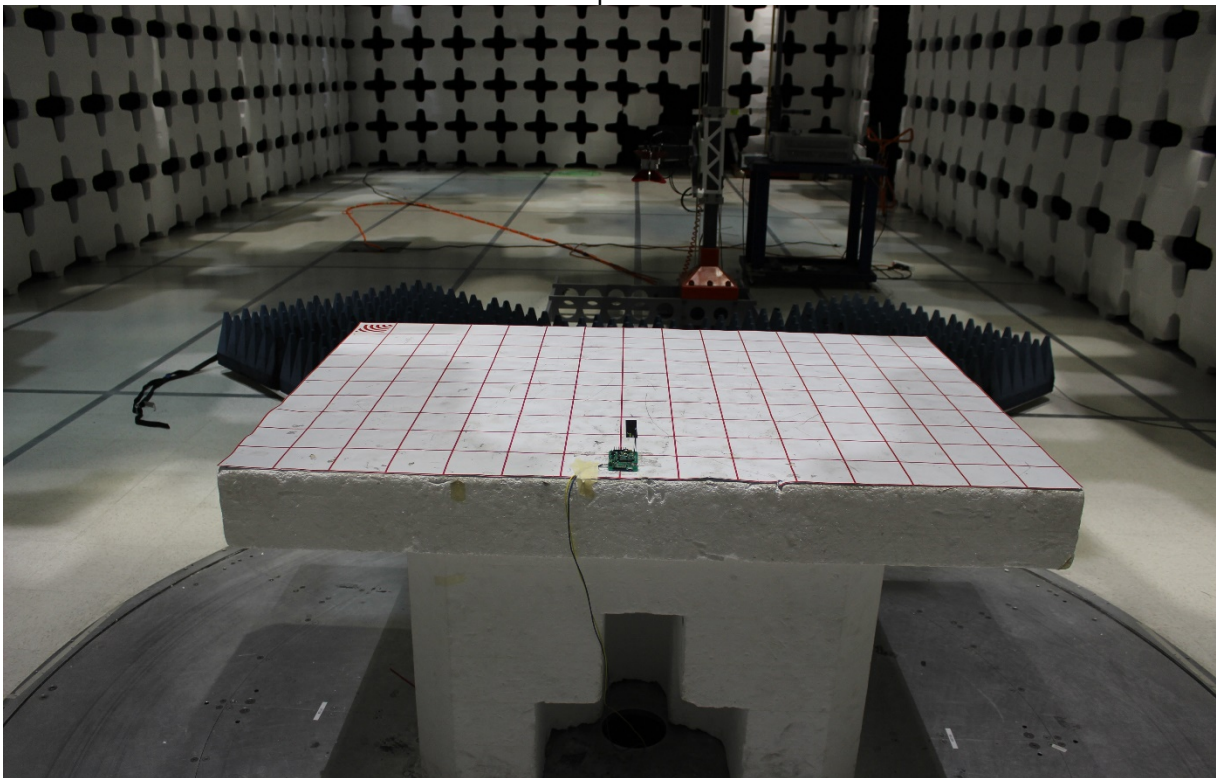

19.5 Radio-frequency, Electromagnetic Field Immunity Test (RS) up to 1GHz

Setup Front

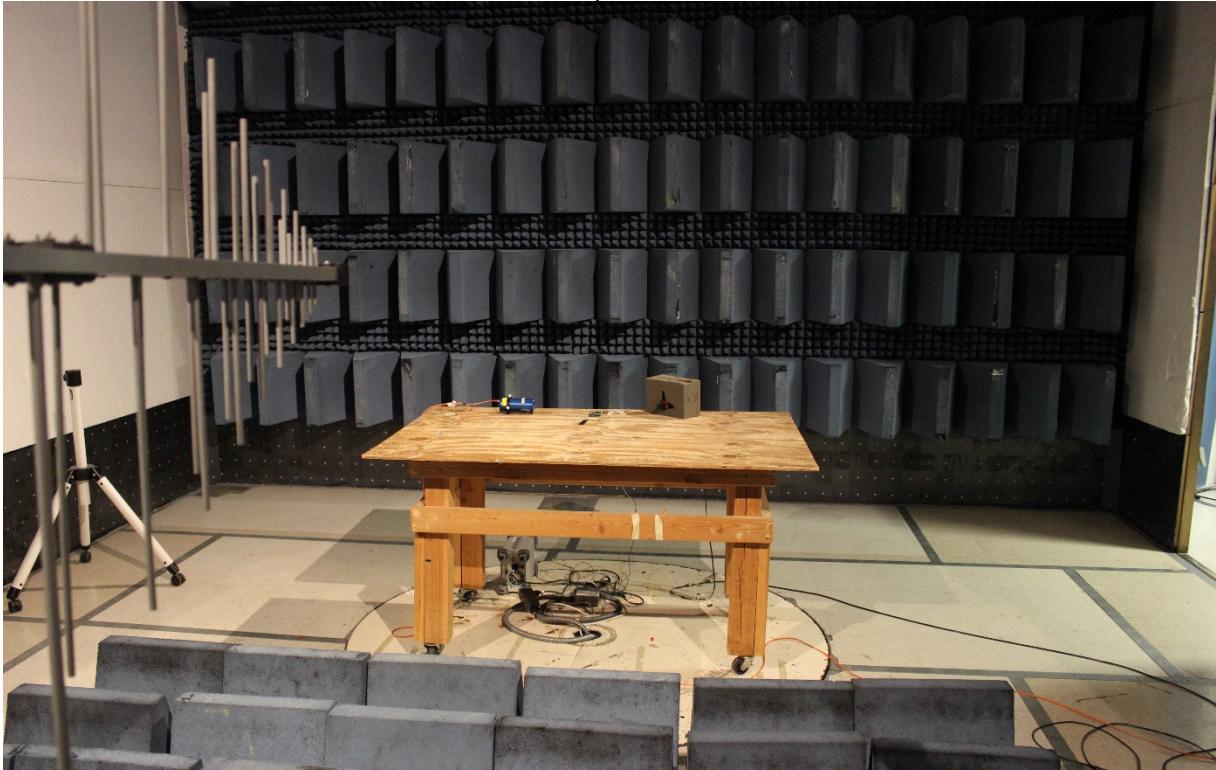

Setup Rear

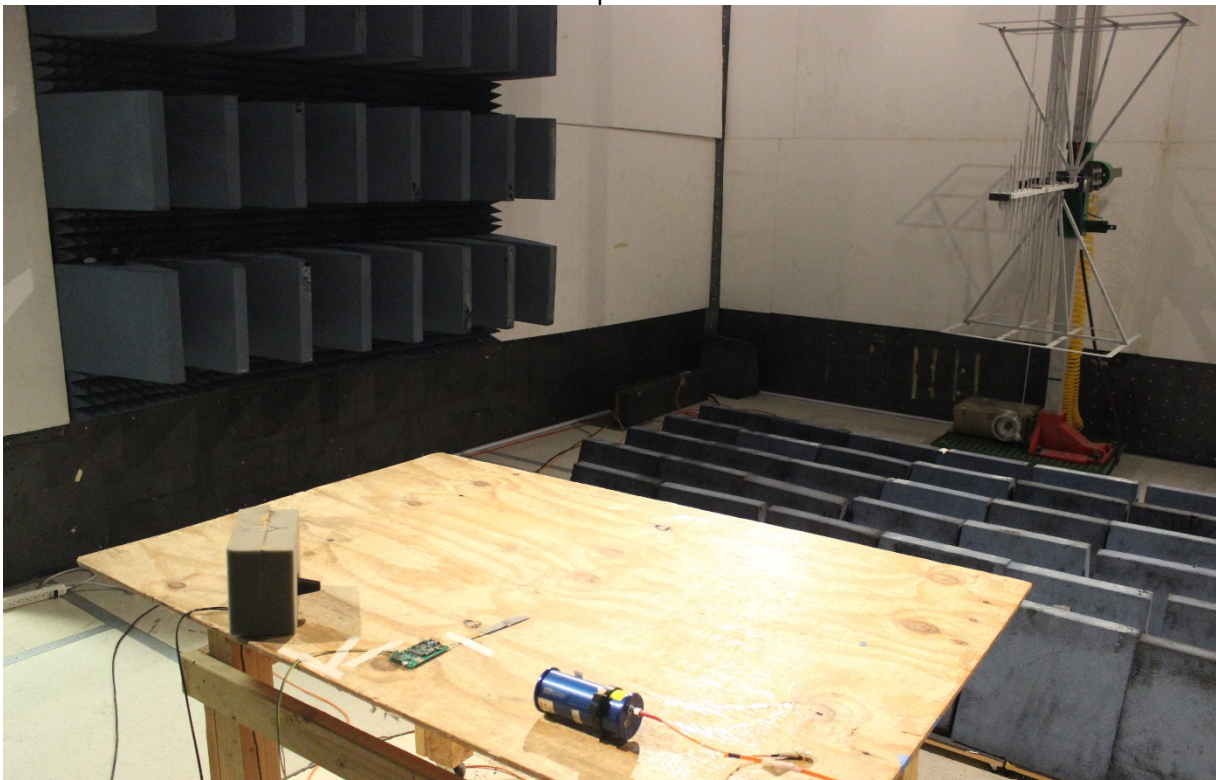

19.6 Radio-frequency, Electromagnetic Field Immunity Test (RS) above 1GHz

Setup Front



Setup Rear



19.7 Electrical Fast Transient/Burst Immunity Test (EFT) Power Port

Setup Front



Setup Side

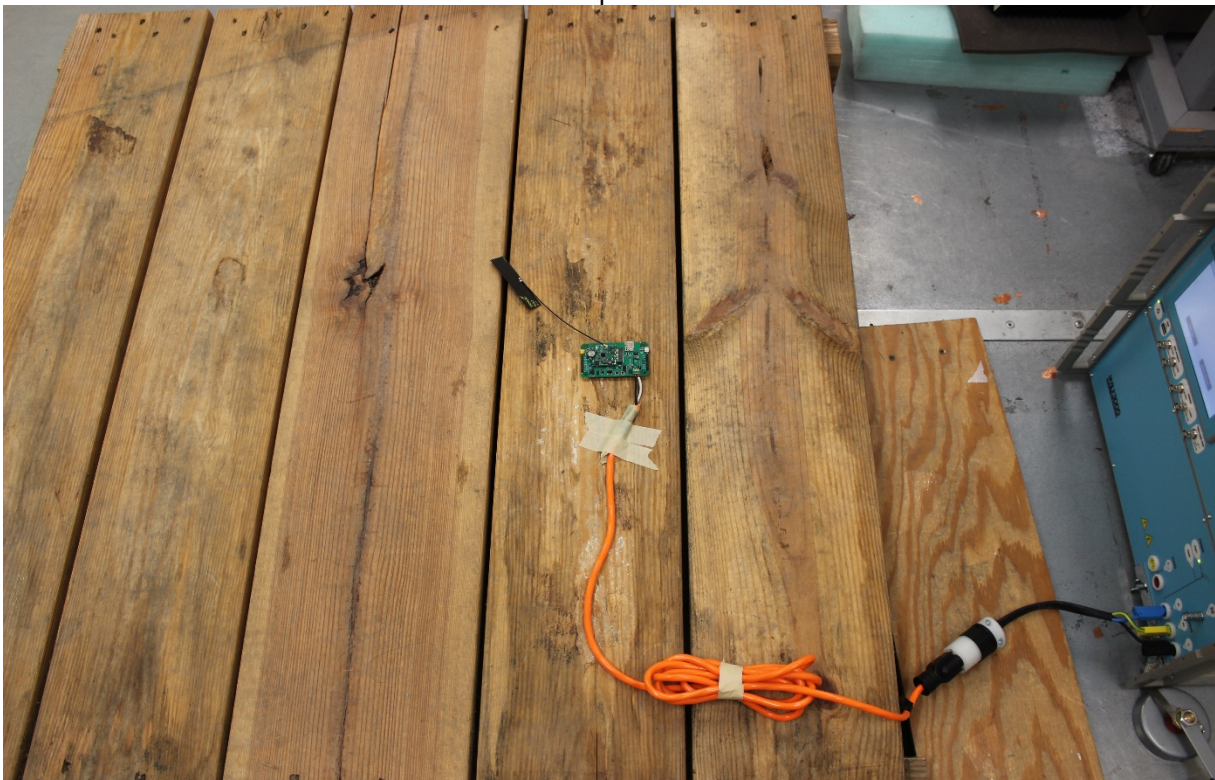

19.8 Conducted Disturbances Induced by RF Fields (CS) Power Port

Setup Front

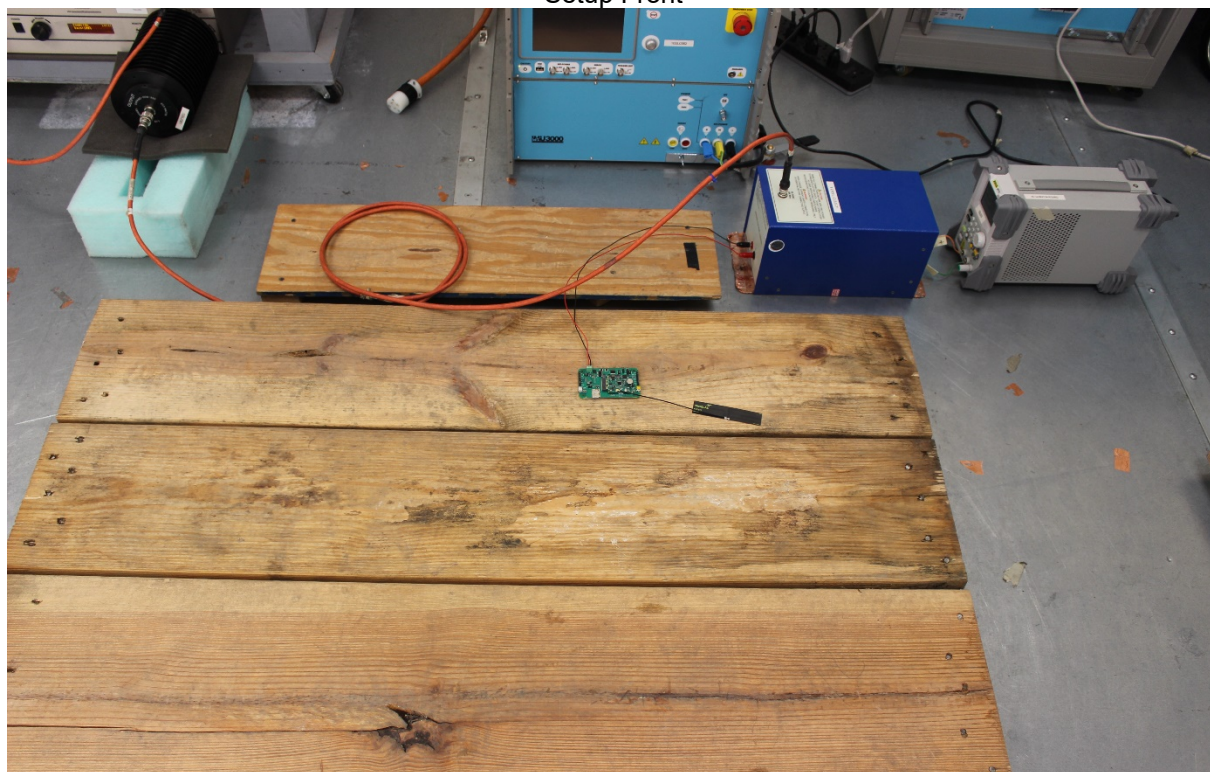

Setup Side



19.9 Appendix – Information of the Testing Laboratories

Bureau Veritas is a global leader in testing, inspection and certification (TIC) services. We help businesses improve safety, sustainability and productivity; and our clients include the majority of leading brands in retail, manufacturing and other industries. With a presence in every major country around the world, our quality assurance and compliance solutions are vital in helping our customers enhance product quality and concept-to-consumer journeys. We also assist with increasing speed to market, profitability and brand equity throughout the supply chain. Bureau Veritas is a leading wireless/IoT testing, inspection, audit and certification provider, with a global network of test laboratories to support the IoT industry in areas of connectivity, security, interoperability as well as quality, health & safety, and environmental/chemical requirements.

If you have any comments, please feel free to contact us at the following:

Milpitas EMC/RF/Safety/Telecom Lab

775 Montague Expressway, Milpitas, CA 95035

Tel: +1 408 526 1188

Sunnyvale OTA/Bluetooth Lab

1293 Anvilwood Avenue, Sunnyvale, CA 94089

Tel: +1 669 600 5293

Littleton EMC/RF/Safety/Environmental Lab

1 Distribution Center Cir #1, Littleton, MA 01460

Tel: +1 978 486 8880

Email: sales.eaw@us.bureauveritas.com

Web Site: www.cpsusa-bureauveritas.com

The address and road map of all our labs can also be found on our web site.

--- End of Test Report ---